

Intelligent IoT-based Power Factor Correction System for Inductive Loads

1st Dr. M. Jothi
Department of Physics
Dhanalakshmi Srinivasan College of Engineering,
Coimbatore, India
jothibalajee@gmail.com

2nd SrinevasanM
Department ofECE,
NANDHA ENGINEERING COLLEGE,
Erode,India.
srinekm@gmail.com

3rd Balajee B
DepartmentofEEE,
Al-Ameen Engineering College,
Erode,India.
balajee4ever@gmail.com

4th Amarnath Prabhakaran A
Department ofBME,
NANDHA ENGINEERING COLLEGE,
Erode,India.
amareceerode@gmail.com

5th SudharsanaVigneshwaran A
DepartmentofECE,
NANDHA ENGINEERING COLLEGE,
Erode,India.
sudharsanavigneshwaran2@gmail.com

6th Samuvel R
DepartmentofECE,
NANDHA ENGINEERING COLLEGE,
Erode,India.
samuelranjith@gmail.com

Abstract: The proposed system combines smart metering with an automatic power factor correction system based on the Internet of Things. It is customized to improve household settings' use of energy efficiently. The IoT system in the suggested system provides automated power factor adjustment, smart energy management, and real-time monitoring. Using voltage sensor modules and current sensor modules, the full Internet of Things with microcontroller detects the voltage and current of the load. To determine the power and power factor used by the electrical load or appliances linked to the load, a mathematical operation is carried out in addition to the sensor value. The Thingspeak application on the IoT platform is used to view the power, power factor, and energy consumption by load throughout the length of the day. The Thingspeak application facilitates easy navigation of the electrical power and power factor for the user. When the power factor value is excessively low, less than 0.95 to 0.85, the Power Factor Correction (PFC) capacitor bank arrangement is connected to the load. When the capacitor is separated from the load, the load's power factor value falls within the acceptable range of 1.0 to 0.95. Because the load current and power factor are inversely related, the power factor affects it. The cost of power consumption will also rise in tandem with an increase in load current. Smart sensors and IoT systems combined with PFC capacitor banks allow customers to reduce costs, increase energy efficiency, and lessen their environmental effects.

Keywords: Smartmeter, InternetofThings, PowerFactorCorrection.

I INTRODUCTION

The primary aim of domestic energy management is to enhance the energy efficiency of buildings and homes. This involves the coordinated operation of hardware and software components within the residential energy management system to effectively regulate energy usage. The concept of "Internet of Things and Everything" (IoT/E) refers to the integration of various systems, devices, and processes into a unified network using IPv6 over the internet. An IoT framework along with smart sensor like voltage and current sensors is commonly deployed in power utility setups to address daily challenges faced by energy consumers. For example, clients typically receive energy usage information only once a month and lack control over deployed smart meters, hindering their ability to detect sudden fluctuations in energy usage. This time gap not only

limits users' ability to observe sudden changes but also prolongs the passage of time. As a result, this

approach guarantees efficient power factor monitoring and computation and enhances it through the use of a power factor correction capacitor (PFC). At the same time, the monitoring of parameters like current, voltage, and power factor keeps on updating through the ThingSpeak web server to the consumer. So that a consumer can easily predict the power demand and utilization of energy for an entire month on a daily basis with hours-based analysis.

II LITERATURE REVIEW

Huy Truong Dinh, Daehee Kim [1] proposed that energy management systems interfaced with the renewable energy saving system enables the electricity vending facility. This proposed method has reduced day to day energy utilization by 46.4% from the normal method. The lack of generation of electrical energy from the conventional method like wind power plant, tidal power plant and water power plant, etc., this proposed method suggest the effective utilization of solar energy from the roof top solar panels [2]. The power sharing can be obtained by estimating the requirement of energy with the help of data mining and data analytics process. R. Godina, E. M. Rodrigues, E. Pouresmaeil, J. C. Matias and J. P. Catalão proposed [3] that electrical power utilization is best than the effective power generation. Because the generation process involves with the lot of human intervention, natural resources and also affects the ecofriendly environment. Hence this method demonstrated with an Air Conditioner (AC) in a room at a normal ambient temperature and this study gives an idea about how can control this way in a advanced predictive controlling mechanism.

A. C. Jose, R. Malekian and B. B. Letswamotse provided a security method [4] that significantly increases home security. This technique entails determining the time, light, and behavior of users within a space in order to facilitate human-powered enhancement of power consumption through efficient electrical energy use. Y. Liu, D. Zhang and H. B. Gooi [5] proposed a Deep learning and Double deep learning algorithm to implement the smart grid and smart home system in connection to Home Energy Management System (HEMS) to avoid the uncertainties in sender and receiver side.

P. Munankarmi, H. Wu, A. Pratt, M. Lunacek, S. P. Balamurugan and P. Spitsen [6] has developed a method that bases the tariff scheme on the electrical appliance's time of usage. The consumer was incentivized by this strategy to

receive benefits beyond the standard electrical energy meter value. This merely minimizes significant variations in power consumption and lowers power usage during peak hours. A. Nag and S. C. Mukhopadhyay suggested a smart home system [7] that would aid sick patients or elderly people who require physical assistance to utilize electrical items. Additionally, it analyses circumference and improves the health of elderly or ill patients.

A. E. Nezhad, A. Rahimnejad, P. H. Nardelli, S. A. Gadsden, S. Sahoo and F. Ghanavati proposed a advanced predictive model to ensure the optimal utilization of electrical energy by using controllable electrical loads. It also provides the information about peak demand of electrical power during demand periods as well as normal day times. This proposed method can improve the home energy management system (HEMS) with the help of advance predictive controlling mechanism on electrical loads. M. Srinevasan, V. Parameshwari, T. Abirami and N. Divyaa [7] the ESP 32 board have been used for IoT interaction. The segregated wastes are collected and identified using supervised machine learning algorithm for categorization of waste.

III EXISTING SYSTEM

The Existing system is made up of an Arduino UNO-powered microcontroller. The module of the 5 Volt DC power supply is linked to this board. This module is sufficient to power the Arduino board, the multi-channel relay circuit, and the current and voltage sensors. An Arduino board and an RTC module (DS3231) are used to see real-time on the LCD. The whole set of data that the Arduino module collects from the current and voltage sensors is recorded using the SD card Trans Flash (TF) module. The Real-Time Clock (RTC) module is used to capture this data about the current value. The user must remove the card from the Trans Flash (TF) module and interface it with a personal computer (PC) if data is required.

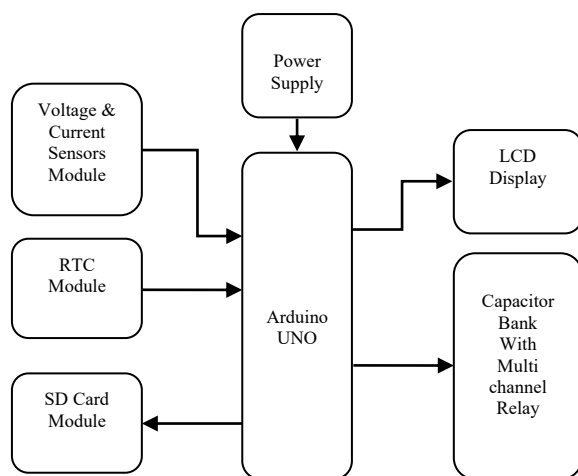

Figure 1. Block Diagram of Existing Method

Here, in order to retrieve the saved data from TTF, the user needs a Personal Computer (PC). The electrical power and power factor has been calculated by simple electrical formula. The RTC module Requires a few momentary type micro switches along

with a pull-down resistor configuration to set the proper hour, minute, and seconds value by using an LCD. Usually, a capacitor connected in series with an electrical supply will give a 90-degree phase difference between input and output current signals. If the inductive load is connected on the load side, the phase difference between the input current and output current value will be 90 degrees lagging with each other. When the inductive load on the output side increases, this will affect the power factor of the supply. If a power system is good when the power factor of the same lies between 1.0 to 0.95. the power system is said to be bad if the power factor value lies between 0.95 – 0.85. It is said to be worse if the value goes below 0.85. the worst value of the power factor simply shows the highest current drawn from the same load. This affects the total power factor of the distribution line. Hence this kind of activity from an industry is not encouraged by the electricity board. More over electricity board will raise a penalty against this industry for bringing down the power factor value to the worst case. The main issue from this scenario is the rising phase current due to the worst power factor will damage the electrical distribution line at the end. To avoid this situation every industry who all are running machines with a greater number of inductive loads will have a set of capacitors connected between the three phases called Power Factor Correction (PFC) capacitor bank to improve or bring up the current value from lagging to leading power factor. In this existing method, a set of Power Factor Correction (PFC) capacitor banks is connected to an Arduino UNO microcontroller through a multi-channel relay circuit. Because relay circuits or modules are used to interface or control the high voltage side to a low voltage side with electrical isolation. Overall, the main drawback of the existing method is that it does not have any hold on tracking power demand and utilization for some time. This just shows only the instantaneous value of the power demand and utilization through an LCD.

IV PROPOSED SYSTEM

The proposed method consists of two major parts.

IV.1. HARDWARE DESCRIPTION

The proposed method has following components,

- Arduino UNO Board.
- Trans Flash (TF) Module.
- Voltage Sensor.
- Current Sensor.
- Zero Crossing Detector.
- Power Factor Correction (PFC) Capacitor Bank.
- Relay Driver Module.
- Node MCU.
- LCD Display.

• ARDUINO UNO BOARD

The Arduino UNO board has a greater number of General-Purpose Input / Output (GPIO) pins compare with other Arduino boards. it also consists of 16 PWM pins along with 54 digital GPIO pins. This enhanced and GPIO and structure is very use full for interfacing more number of sensors and actuators [8]. In this proposed system, it consists of voltage and current sensor along with LCD, multi-channel relay, TF module, Zero coring detector circuit. Hence it requires huge

number of General-Purpose Input / Output pins to get desired output.

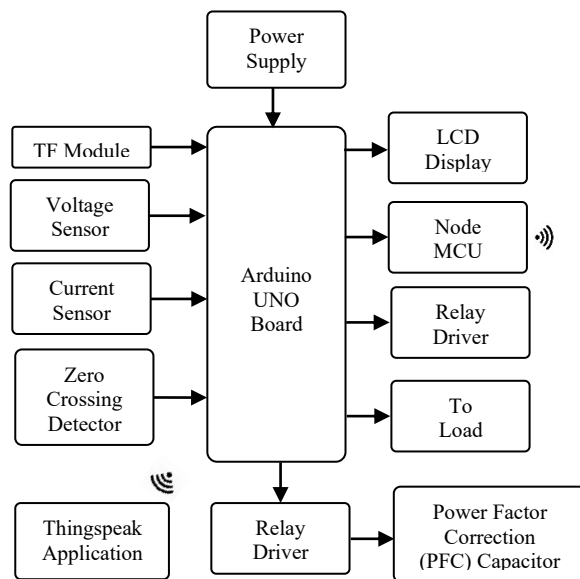

Figure 2. Block Diagram of Proposed Method

B. NODE MCU

Node MCU which is made up of ESP8266 SoC from Espressif Systems, offers an open-source platform for development of hardware and firmware development. This ESP 8266 consists of a microcontroller along with Wi-Fi Connectivity which will supports for internet of Things (IoT) applications. Lot of IoT frameworks [9] are available in free of cost around the web like IFTTT, Yuvibot, Thingspeak, etc., However, its complexity makes accessing and utilizing the ESP8266 chip challenging.

C. REGULATED POWER SUPPLY

Through the use of a rectifier, an unregulated AC source is converted by a regulated power supply circuit to a steady DC output. Its primary responsibility is to supply devices within designated power supply dawns with a steady voltage (or occasionally current). The output mostly produces DC, though it can also be unidirectional or alternating. Stabilization techniques maintain output uniformity under a range of load scenarios; modern techniques frequently include supply source [10] fluctuation correction.

D. MULTI-CHANNEL RELAY

Relays are electromechanical devices that serve to isolate the input and output sides electrically. The relay in an electronic circuit can be powered by a 5V or 12V DC source to run its coil. A relay also essentially comes in two varieties. Both Double Pole Double Through (DPDT) and Single Pole Double Through (SPDT) switches are available. The input and output sides are often separated using an opto coupler device to prevent interference between the circuits.

E. LCD

The Liquid Crystal Display used for display mono chrome text with respect to ASCII values. This operated by Arduino MEGA board by means of program. Hence it Is a 16x2 display and can display the alphanumeric characters up to 32. This can also display number, alphabets, symbol and some special characters. Based on the LED placed behind LCD panel it may have the background like white, blue, green and even in black.

F. CURRENT SENSOR

A current sensor (ACS712) converts current to a measurable voltage output, the same is proportional to the current flows through a path, with various sensors tailored for specific current ranges and environmental conditions. Here in this proposed model acs712 used to measure the total load current consumed by the electrical appliances. The ACS712 uses analogue read operation to measure the load current. This provides an analogue value between 0 and 1023 with a 10 bit resolution in the ADC connected to the analogue pins of the Arduino. Up to a 30A AC supply, the same sensor can measure load current. This current sensor has a maximum biasing voltage of 5V DC. This device is equipped with an internal current transformer that detects the load current that is connected to it.

G. VOLTAGE SENSOR

A voltage sensor (ZMPT101B) measures voltage levels in electrical circuits, crucial for diverse applications such as industrial controls and power systems. With its internal potential transformer, this voltage sensor can measure input voltage from an AC supply ranging from 0 to 250V. This gives the analogue value between 0 and 1024. To determine the input voltage straight from the analogue value, the Arduino software needs a small library file. These devices are vital for gauging high voltages and detecting low current levels, ensuring efficient operation of equipment and machinery. Employed in various scenarios, voltage sensors play a pivotal role in monitoring and controlling electrical systems, enhancing safety and performance across industries.

H. ZERO CROSS DETECTOR

A zero-cross detector circuit identifies when the AC signal reaches the zero point, frequently applied for controlling AC power equipment. In a digital circuit, the alternating signals are measured like its frequency parameter with help of Zero Crossing Detector circuit. Usually an 555 Timer Ic will be used to produce a Zero Crossing Detector circuit.

I. POWER FACTOR CORRECTION (PFC) CAPACITIVE BANK

A capacitor plays a vital role in industrial power systems. Most of the industrial machinery constructed with the help of induction motor. Usually, an induction motor will provide the lagging power factor to the power system. A group of induction motor will make the lagging power factor of the system to too poor. When the power factor of the total load is power it will draw more power from the electrical source for the same amount of current

.in order to avoid this situation a capacitor will connected in series with each phase. This series connection of capacitor with the supply will bring up the power factor from lagging to leading situation. For a three phase load the capacitors are arranged with star connection and connected between three phases to improvise the load power factor. capacitive bank includes capacitors linked in parallel or series, designed to rapidly store and discharge electrical energy, commonly utilized for power factor enhancement or energy buildup in pulsed power scenarios.

IV.2.METHODOLOGY

This proposed system involves a prognostic approach to residential energy management system, using an Arduino based control and monitoring arrangement to ensure the effective utilization of energy consumption. This proposed system has an IoT-driven solution aimed at establishing an intelligent energy management system, effectively reducing costs within specified time frames. The Arduino UNO board in the proposed system keeps an eye on the load's voltage and current parameters. A current sensor (ACS712) is included in this circuit that can monitor the load AC current value up to 30A, and a voltage sensor (ZMPT101B) can be used to monitor the voltage in the input AC line. The power factor of the load that is connected to the supply is always dependent on the type of load that is connected to it. For example, in case (1), if the load is resistive, the load voltage and current value will be in phase with each other, meaning that the ratio of the load voltage and current will be zero, and therefore $\cos(0^\circ)$ will be 1. This indicates that the load will use the optimal amount of current from the supply. In case (2), if the load is capacitive, the load current will be leading with the load voltage, meaning that the load is actually supplying energy to the supply terminal rather than drawing current from the supply, which is not practically possible. In case (3), the load current will be trailing the load voltage if the load attached to the supply is inductive.

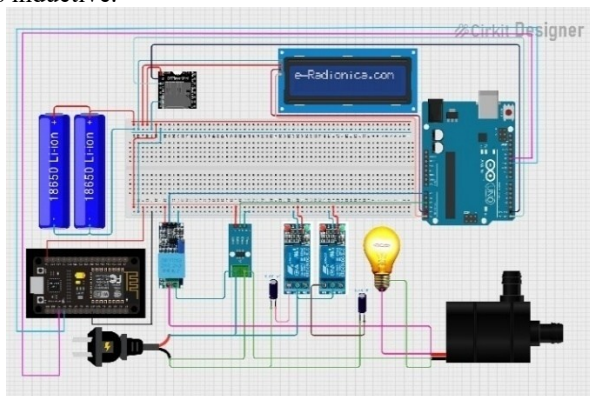

Figure 3. Circuit Diagram of Proposed Method

Usually, the power factor will be a numeric number and does not have any electrical unit. Figure 3 displays the proposed system's circuit a notional household single-phase load is permitted to take up to 6A of current in accordance with the electrical board's regulations. For measuring the overall current value

This situation is noteworthy because the same load will require more current from the supply if the power factor falls below 0.95. The electrical load's tariff and performance will be impacted. The real power can be obtained by multiplication of load voltage and current. And apparent power can be calculated by $\sqrt{3} \times \text{Voltage} \times \text{Load Current}$. Finally the power factor can be obtained by small mathematical equation, that is

$$\text{Power Factor} = \frac{\text{Real Power in Watts}}{\text{Apparant Power in VA}}$$

used by a single home or residence, the ACS712 current sensor is therefore more than sufficient. The current sensor will give an analogue value to the microcontroller that lies between 0 and 5V DC. The sensor will give the sensitivity for 185 mV on the output for a 1 ampere current change in the load. A simple formula is used, manipulate the power and power factor. The LCD display will display the load parameters, which include voltage, current, and the computed power with power factor. For the purpose of data logging, the aforementioned parameters are also sent to the Thingspeak program.

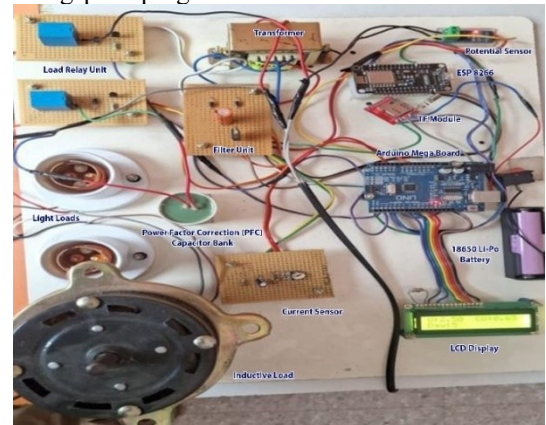

(a)



(b)

Figure 4.a Prototype of Proposed System

4.b screenshot of Thingspeak application

A user can then forecast when their energy usage will be highest. The Arduino board in the present circuit will trigger the relay module which is connected to the PFC(Power Factor Correction) capacitor bank. The voltage sensor module ZMPT101B and the current sensor module ACS712 continually monitor the voltage and current of the load. At the same time, the apparent and real power of the load is calculated mathematically and

compared to the reference values. Until the power factor varies between 0.95 and 1, the relay will remain in its ideal state. This means that the Power Factor Correction (PFC) capacitor will not be attached to the load terminal. The relay will turn on and connect the Power Factor Correction Capacitor to the load line when the calculated power factor value drops below 0.95. A relay circuit controlled by the Arduino board will be used to add a power factor adjustment capacitor to the load in parallel when this circumstance arises. Thingspeak is an IoT analytics platform that makes it easier to collect, visualize, and analyse real-time data streams in a cloud setting. It permits the running of code for online data processing and analysis, and it provides instantaneous visualization of data supplied by devices. The figure 4.a has a set of Arduino UNO board along with ESP8266 for IoT Communication, smart sensors Correction (PFC) capacitor. Thingspeak is often used for IoT system validation and prototyping, enabling analytics-driven proof of concept projects. The inductive and resistive loads are connected to microcontroller unit through multi-channel relay circuit. This voltage and current value given to a small mathematical calculation so that power, power factor of the load can be calculated accurately. All the inductive loads are running at lagging power factor. Figure 4.b has the power factor and energy of load will be calculated. A graphical representation of the active participation of Power Factor Correction Capacitors with load is provided using a Thingspeak framework. Data collected from several smart sensors by the Arduino UNO is sent and received via a Node MCU. In order to connect the high voltage side to the low voltage side, a multi-channel relay module is utilized. The filter and regulator unit are part of the 12 V DC power supply that powers the suggested system. A 12V DC power source power up a multi-channel relay module; the other microcontrollers, node MCUs, and sensor units are powered by a 5V precise supply. On the other hand, a single 18650 lithium polymer battery powers the entire module, allowing it to function even in the absence of an electrical power source. The tiny power supply unit is what maintains the ESP8266 board's constant cloud network connection. Thingspeak will serve as the cloud network platform in this instance. In order to examine all of the information from the Arduino UNO board via the framework using an ESP8266 and the internet, a user mail is allocated with a framework.

V RESULT AND DISCUSSION

A load current and voltage are being monitored accurately with the help of ZMPT101B (voltage sensor) and ACS712 (current sensor). The Arduino UNO board can handle the analog input data in a 10-bit resolution. This voltage sensor can measure the input voltage up to 330V. Also, an output of the same sensor will be between 0 and 5V DC. Here a simple manipulation is required to find the input AC voltage equivalent analogue value. Whatever the input voltage appears to be in the input,

that should be multiplied with the decimal number 0.000625 to get the exact input voltage that appears to the analog input pin. From the voltage and current obtained from the sensor as said earlier a mathematical formula is required to calculate real and apparent power. The function called pulse is used in the Arduino sketch to find the phase difference between the two voltages of the load connected to the supply. If the load current measured by the ACS712's phase is lagging with the load voltage, it means that an inductive load is connected on the load side. And here the monitoring of load current is very important. When the power factor goes below 0.95 during the lagging power factor, the load will draw more current for the same load. In this situation, once the power factor gets down beyond 0.95, the Arduino will sense this value through a voltage and current sensor. At this instant the Power Factor Correction (PFC) Capacitor will connect in parallel between load terminals. This capacitor will absorb reactive power produced from connected loads. Hence, this will prevent the power factor from getting down below 0.95 and improve the efficiency of the power system. A parallel capacitor on the load side will decrease the loss and absorb reactive energy produced on the load side. Another important scenario is that a capacitor will charge at first and then release charged voltage when it reaches the maximum voltage value of the capacitor. The Thingspeak framework is the source of Figure 4.b. This merely demonstrates the engagement of a Power Factor Correction (PFC) capacitor in conjunction with a load unit linked to the suggested system. A multichannel relay unit and a Power Factor Correction (PFC) capacitor unit are added to the hardware portion. The microcontroller uses the value computed by the current and voltage sensors to determine when to raise the flag. As previously stated, when the power factor value determined by the sensors falls between 0.95 and 0.85, the Power Factor Correction (PFC) capacitor is connected to the load. This configuration merely raises the load's power factor. When a capacitor is linked to a load in parallel, it will provide the load with the leading power factor. A PFC bank will observe the reactive power by supplying its charged voltage to the supply. Moreover, the power factor is the ratio between real and reactive power. The efficiency or power factor will increase when the reactive power observed by the load is decreased. A ThingSpeak web framework on the consumer end can provide the electrical energy demand date-wise with hour-wise analysis in a day. From the ThingSpeak page, a consumer can analyze their load's maximum demand time and also the energy consumption throughout the day in a week, as can be seen in Figure 4.b in the preceding graph. Here, it only assists us in determining the most energy-demanding hours based on the volume of energy consumption during the day.

VI CONCLUSION

An electrical system must operate as efficiently as possible. To ensure the effective utilization of electrical power. It's necessary to reduce the reactive power consumption by the load as much as possible. Because a power factor is a parameter that depends on the ratio between the real and reactive power of the electrical load, the

increasing reactive load will lead to a growing loss in the electrical system because the output of a power system depends on the difference between input and loss. Hence, adding a capacitor on the load side of the power system will increase the terminal voltage and increase the absorption of loss produced by the load by consuming the reactive power. So the Power Factor Correction (PFC) capacitor plays a vital role in improving the power factor in an electrical system, especially for domestic loads. Even though domestic loads are secondary consumers of electrical power systems, it is also essential to consider the power factor on the load side. For a power system to operate smoothly, preventing energy waste and maintaining a high-power factor is therefore essential. The proposed system calculates the power and power factor utilized by the load using smart sensors (ZMPT101B – Voltage Sensor & ACS712 - Current Sensor) that are all connected to an Arduino UNO board. The complete computed value is displayed on the ThingSpeak framework screen for the user's reference, and the same information is kept in cloud storage for data analysis concerning energy demand and utilization of energy throughout the day. It can monitor the load and power factor value with the help of this sophisticated smart sensor along with a power factor correction (PFC) capacitor for positively regulating the power factor. The Arduino UNO board monitors and actuates the relay at the right time to prevent the load power factor from going beyond a lower level, and the Internet of Things module is used to receive and process the data along with a ThingSpeak graph for data analysis. Because of this, a low power factor causes the load current to increase, which in turn damages the entire power system. The user is penalized by the electrical power system unit for continuing to maintain a low power factor. Thus, the mechanism for controlling and monitoring the load and its power factor is provided by the proposed method. The Internet of Things platform, which provides cumulative data for a specified period from the cloud, has expanded this facility. This chart helps the users to analyze and take action against the demand. The proposed system minimizes tariff amounts while simultaneously shielding users from penalties imposed by the state's electricity grid. All things considered, the suggested system aids in the power system's overall safe and efficient operation.

REFERENCE

1. Dinh, H.T. and D. Kim, *An optimal energy-saving home energy management supporting user comfort and electricity selling with different prices*. IEEE Access, 2021. **9**: p. 9235-9249.
2. Gautam, M., et al. *Data acquisition for residential energy management employing iot using thingspeak*. in *2019 IEEE Region 10 Symposium (TENSymp)*. 2019. IEEE.
3. Godina, R., et al., *Model predictive control home energy management and optimization strategy with demand response*. Applied Sciences, 2018. **8**(3): p. 408.
4. Jose, A.C., R. Malekian, and B.B. Letswamotse, *Improving smart home security; integrating behaviour prediction into smart home*. International Journal of Sensor Networks, 2018. **28**(4): p. 253-269.
5. Liu, Y., D. Zhang, and H.B. Gooi, *Optimization strategy based on deep reinforcement learning for home energy management*. CSEE Journal of Power and Energy Systems, 2020. **6**(3): p. 572-582.
6. Munankarmi, P., et al., *Home energy management system for price-responsive operation of consumer technologies under an export rate*. IEEE Access, 2022. **10**: p. 50087-50099.
7. Srinevasan, M., et al. *Artificial Intelligence and Supervised Learning based Solid Waste Segregation Mechanism using ESP 32*. in *2023 Third International Conference on Ubiquitous Computing and Intelligent Information Systems (ICUIS)*. 2023. IEEE.
8. Parameshwari, M.V., et al., *An intelligent bionic person for bomb detection and diffusion using internet of things (IoT) in military application*. International Journal of Mechanical Engineering, 2021. **6**(85): p. 1029-1038.
9. Parameshwari, V., et al., *IoT enabled intelligent irrigation system for agriculture fields*. Journal of Advanced Research in Dynamical and Control Systems, 2019. **11**(8): p. 269-279.
10. Nag, A. and S.C. Mukhopadhyay, *Smart Home: Recognition of activities of elderly for 24/7; Coverage issues*. International Journal on Smart Sensing and Intelligent Systems, 2014. **7**(5): p. 1-10.
11. Nezhad, A.E., et al., *A shrinking horizon model predictive controller for daily scheduling of home energy management systems*. IEEE Access, 2022. **10**: p. 29716-29730.
12. Percy, S.D., M. Aldeen, and A. Berry, *Residential demand forecasting with solar-battery systems: A survey-less approach*. IEEE Transactions on Sustainable Energy, 2018. **9**(4): p. 1499-1507.
13. Sumarmad, K.A.A., et al., *Microgrid energy management system based on fuzzy logic and monitoring platform for data analysis*. Energies, 2022. **15**(11): p. 4125.
14. Srinevasan, M., B. Sowparnika, and B. Balajee. *Enhancing Skin Cancer Diagnosis Using DL with 3D Model*. in *2023 International Conference on Self Sustainable Artificial Intelligence Systems (ICSSAS)*. 2023. IEEE.